



Install a Rheem

Instruction Manual for Electric Storage Water Heater



MODELS: -

- ★ EH-25M
- ★ EH-40M
- ★ EH-55M
- ★ EH-75M
- ★ EH-100M

Please Read This Manual Carefully Before Installation and Application

Rheem Manufacturing Co. Singapore Pte Ltd

Content

Thank you for choosing a Rheem Electric Storage Water Heater. This is the latest product of our company designed to provide you with hot water round the clock.

Please read this manual carefully before installation and usage. In particular, please pay special attention to the Safety and Warnings. The installation must be undertaken by an authorized person. Please leave this manual with the houseowner upon the completion of installation.

1. Features -----	3
2. Safety -----	3
3. Technical Data and Dimensions -----	5
4. Installation and Connection -----	6
5. Operation -----	10
6. Maintenance -----	10
7. Common Breakdowns and Remedies -----	11
8. Limited Warranty -----	11

Features

- Operating at mains water pressure, providing stable hot water supply.
- Large storage capacity, deliver hot water simultaneously for multiple point usage.
- The thermostat automatically controls the power supply to the heating unit so that constant temperature is maintained.
- Safety devices such as over temperature cut out, and temperature & pressure relief valve are standard features.
- The temperature is factory preset at 65°C for reasons of safety.
- The life span of the tank is greatly extended by "Rheemglas" enamel lining and sacrificial magnesium anode.
- Polyurethane foaming material free of CFC makes the water heater more efficient and cost-saving, and environmentally friendly.
- Colorbond jacket is rust-proof and fade resistant.

Safety

- This appliance is not intended for use by persons (including children) with reduced physical, sensory or mental capabilities, or lack of experience and knowledge, unless they have been given supervision or instruction concerning use of the appliance by a person responsible for their safety. Children should be supervised to ensure that they do not play with the appliance.
- CAUTION: In order to avoid a hazard due to inadvertent resetting of the thermal cutout, this appliance must not be supplied through an external switching device, such as a timer, or connected to a circuit that is regularly switched on and off by the utility. The water heater location must have a floor trap nearby for discharging water in the event that the water heater or pipe leaks
- The water heater is powered to 220~240VAC/50Hz.

- Electricity meter, power cables and terminal block must comply with rated electric current.
- A separate terminal block must be applied. The terminal block should have an earth connection that is strictly separated from the neutral. Please see "Electrical Connection" for more details.
- Keep the terminal block and electric plug in a dry place. Do not touch electric plug with wet hands!
- Power must not be turned on until the water heater is filled with water.
- Temperature over 50°C may cause scalding! Please mix cold water with hot water to desirable shower/bath temperature.
- Please operate the temperature pressure (T&P) relief valve at least once every six month to remove the lime deposits and verify that the drain pipe is not blocked.
- Blockage of overflow pipe will lead to tank expansion! Warranty is void!
- Power must be turned off before any service and maintenance work can commence!
- Any replacement of parts must be original parts from the manufacturer!
- Water may drip from the discharge pipe of the T&P relief valve. The discharge pipe should be connected to an overflow discharge pipe.

The water in heater can be drained by following steps:

1. Turn off the incoming water stop-cock or ball valve
2. Open any hot water mixer tap, then lift-up the lever of T&P relief valve to drain of about a quarter of water inside tank
3. Disconnect the cold water inlet coupling. Use a rubber hose to plug into the water heater inlet and other end place near to the drain. The water will flow out through the hose and thus drain off all water.

Technical Data and Dimensions

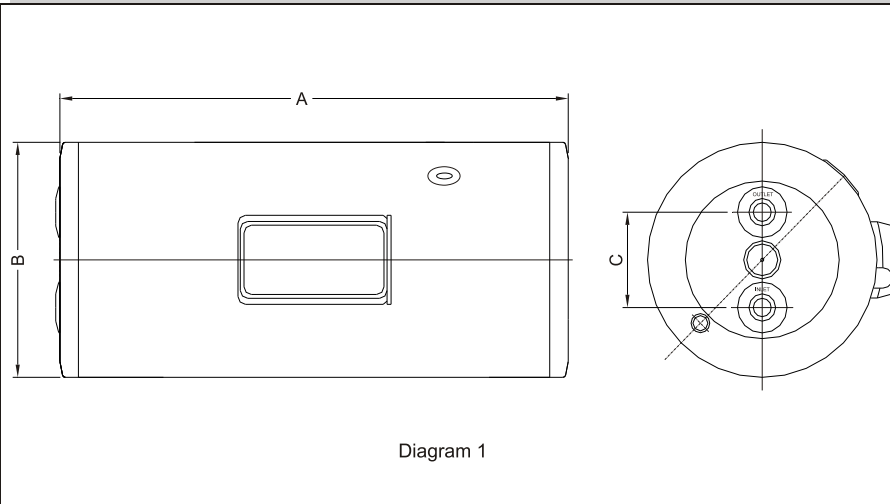

Model Number		EH-25M	EH-40M	EH-55M	EH-75M	EH-100M
Rated Storage	L	25	40	55	75	100
Rated Power	kW	2.5/3.0				
Rated Electric Current	A	11.4 - 12.5				
Time of hot water at 40°C rise	min.	24	38	52	71	95
Length A	mm	437	640	777	1116	962
Diameter B	mm	∅370				∅458
C	mm	150				240
Power Supply		220 - 240V ~ / 50Hz				
Temp. Setting	°C	65				
Max. inlet water pressure	kPa	800				
T&P Relief valve Pressure	kPa	1000				
Pipe sizes for inlet and outlet		3/4" /20 BSP				
Pipe size for safety valve		3/4" /20 BSP				
Shipping Weight	kg	17	22	25	31	36

* Each model of electric water heaters can be fitted with different rating of heating elements: 1.5 kW, 2.5 /3.0kW, 4.8 kW, and the matched minimum section acreage of copper core main power wire is of 1.5mm², 2.5mm², 4.0mm² respectively.

■ Due to product improvement, please check that installation manual has been updated.

Installation and Connection

Choose where to install

- The water heater must be installed indoor.
- The wall must be strong enough to support heater.
- The heater is to be installed near to points of use.
- Ensure that sufficient space is available for servicing.
The distance between the right end of the heater and the adjacent wall must not be less than 500mm.
- There must be a floor trap near installation point for the heater drain pipe.
- Water heater/power switch/electric leakage protector should be protected against water.

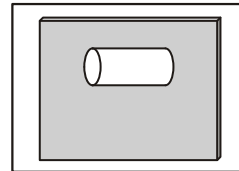

Diagram 2

Installation

- Mark the drilling position for locating expansion bolts on the wall or ceiling as shown in diagram 3. The two upper holes must be in the same horizontal line.

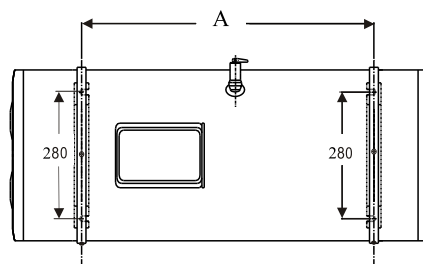

Diagram 3

Type	Hole Space, A
25L	320 mm
40L	340 mm
55L	477 mm
75L	812 mm
100L	632 mm

- Drill holes on the wall using a $\varnothing 12$ mm drill bit (do not damage the electric cable and pipe work inside the wall), then screw in expansion bolts and fasten the hooks on the wall.
- Hang up the heater as shown in Diagram 4. The mounted heater must be horizontal.
- Use ST4.2 self-tap screw to secure the water heater to the universal brackets.

Optional:

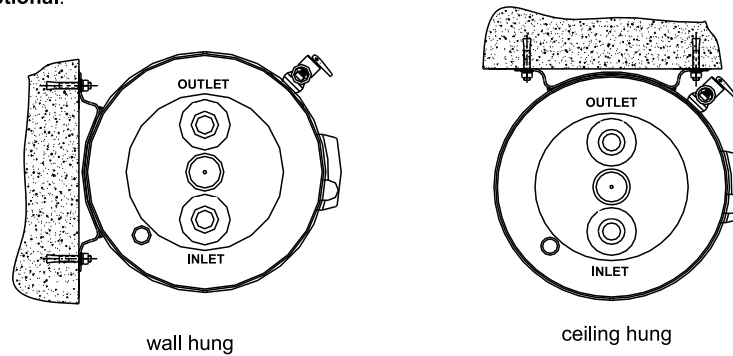

Diagram 4

Connection—Plumbing

- Pipe Material
The pipes connecting to the inlet and outlet of the water heater must be strong enough to withstand water pressure up to 1.40 MPa.
- Pipe Size
3/4" (20mm) pipes are to be used for cold water inlet, hot water outlet and T&P Relief valve.
- Connection
Both the inlet and outlet are located at the end of the water heater, with the upper connection being outlet and lower connection being inlet. The cold water tap is fitted to the inlet as shown in diagram 5. As the temperature is high at the outlet, a mixing valve which mixes hot water with cold water is suggested to be fitted. If the outlet tap is not close to the water heater, thermal insulation material is recommended to insulate the hot water pipe so as to reduce heat loss.
- **This water heater is designed to operate at mains pressure by connecting directly to the mains water supply, if the mains supply pressure in your area exceeds 800kPa, a pressure limiting valve must be fitted. The supply pressure should be greater than 350kPa for true mains pressure operation.**

If the mains pressure is too low, the amount of hot water delivered to multiple points will be unsatisfactory. Thus a booster pump is suggested to be increase the pressure. A pressure-limiting valve is suggested to be fitted if the main pressure exceeds the rated maximum pressure.

Option A

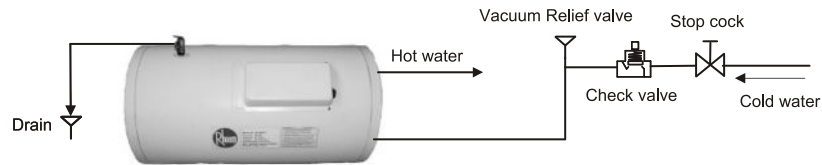

Option B

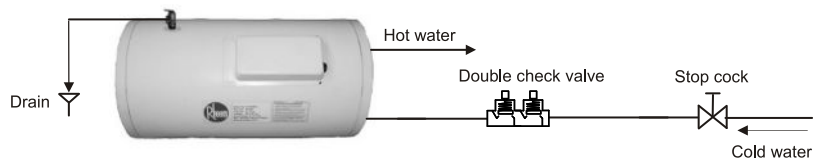

Diagram 5

- Temperature & Pressure(T&P) Relief valve drain
A drainpipe must be fitted for the water discharge. The pipework from the T&P relief valve to the floor trap should be as short as possible, with no restrictions. It should have no more than three right angle bends in it. Use 15mm OD(1/2") pipe.

Connection—Electrical

Do not turn on power supply to the water heater until the water heater is filled with water and a satisfactory megger reading is obtained.

- Electrical wiring works must be undertaken by a qualified electrician.
- The water heater is rated for single phase 220-240VAC, 50Hz.
- The heater must be permanently connected to the electricity supply through a double pole linked switch having a contact separation of at least 3 mm in all poles incorporated in the circuit and out of reach from the person using the shower.
 - a) The use of plug and socket is not recommended.
 - b) The appliance must be earthed.
 - c) All wiring must conform to local requirements. If in doubt, please consult a qualified electrician.

Option A: This diagram is for Robertshaw "EWT" Thermostats

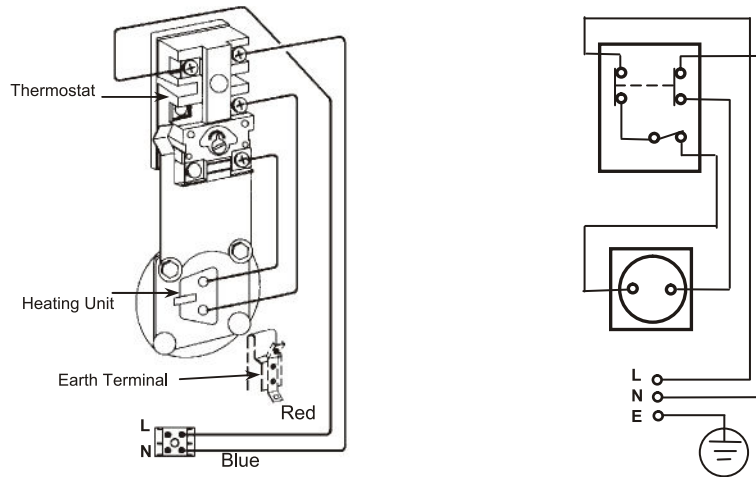

Option B: This diagram is for Robertshaw "ST" Thermostats

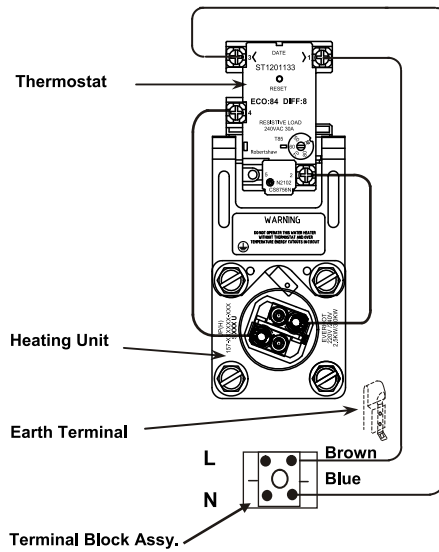

Diagram 6 Electrical connection

Operation

Filling the Water Heater

- Open one of the hot water mixer taps.
- Open the cold water tap to the water heater.
- When water flows out of the hot water mixer, it means that water heater is completely filled.

Warnings: Power must not be switched on until the water heater is filled with water. There will be NO WARRANTY for dry firing.

Using Hot Water

- The water heater operates on/off automatically.
- In normal condition, the cold water tap should remain open.
- It is normal for the T&PR valve to release a small amount of hot water during the heating cycle due to expansion.
- Always open mixer to cold water first and slowly adjust to warm to avoid scalding.
- When water supply is interrupted, the main power supply to the heater should be switched off to avoid dry firing.

Shut off the Water Heater

The water heater should be shut off if it is serviced or it is not used for a long period of time. Shut off the water heater according to following steps:

- Plug off the electric cable
- Switch off the stop tap of cold water inlet

Maintenance

Temperature and Pressure (T&P) Relief Valve

- Operate the T&P Relief Valve at least once every six months to remove lime deposits and verify that it is not blocked. This is done by lifting the lever at the T&P valve for a few second. If there is no water flowing out, please call for a serviceman.
- Damage to the heaters due to blockage in the overflow pipe will void the warranty.

Common breakdowns and remedies

Breakdowns	Possible Causes	Remedies
No hot water flowing out	<ol style="list-style-type: none"> 1) Cold water inlet tap is shut off 2) Pipes are blocked 3) Water supply is cut off 	<ol style="list-style-type: none"> 1) Turn on the inlet tap 2) Dredge the pipe by plumbers
Water is not hot	<ol style="list-style-type: none"> 1) Electric plug is off at the socket 2) Terminal block is damaged 3) ELCB has operated. Element has failed 4) ECO has activated (Hi Limit) 5) Temperature set is too low 6) Thermostat is damaged 7) Water Heater is working 	<ol style="list-style-type: none"> 1) Plug in 2) Call electrician 3) Call electrician 4) Call electrician 5) Raise the set temperature 6) Call electrician 7) Please wait for a while
Sound from the water heater and pipelines	<ol style="list-style-type: none"> 1) Heating up noise 2) Abnormal sound in pipeline when mains pressure is not stable. 3) Scaling on elements 	<ol style="list-style-type: none"> 1) Normal 2) Normal. Close the cold water inlet tap for a while. 3) Call for a serviceman
T&P Relief valve discharge water	<ol style="list-style-type: none"> 1) Expansion of water during heating up 2) Valve is blocked by foreign materials 3) Excessive cold water pressure 	<ol style="list-style-type: none"> 1) Normal 2) Operate valve lever to remove dirt deposit 3) Reduce incoming water pressure

Limited Warranty

RHEEM MANUFACTURING COMPANY (SINGAPORE) PTE LTD, representing RHEEM Water Heater will guarantee the heater for a period of twelve months from date of original installation and operation against defect through faulty materials and workmanship.

RHEEM MANUFACTURING COMPANY (SINGAPORE) PTE LTD will warrant to replace any part or parts which prove to have been defective and which have not been misused or carelessly handled. We reserve the right to decline responsibility where installation has been incorrectly carried out and not in accordance with the manufacture's instructions, which accompany each heater.

Rheem Water Heater

Rheem Manufacturing Company (Singapore) Pte Ltd

Revision Date: **Sep 2019**

1120052_C