

Owner's Guide and Installation Instructions

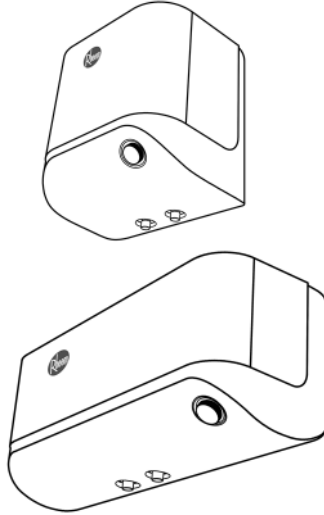

MODELS
XC-10, XC-15, XC-30
XS-20, XS-30

Rheem XWELL™
Electric Storage Water Heaters



*This water heater must be installed and serviced by a qualified person.
Please leave this guide with the householder.*

CONTENTS

HOUSEHOLDER

This booklet contains important information about your new water heater.
We recommend you read pages 3 to 11.

The other pages are intended for the installer but may be of interest.

Contents	2
Safety, Warnings and Pressure Relief Valve	3
About Your Water Heater	5
Maintenance Requirements	8
Save A Service Call	10
Installation – General	12
Connections – Plumbing.....	17
Connections – Electricity.....	20
Commissioning.....	21
Draining The Water Heater.....	22
Warranty	24

An electronic copy of these Owner's Guide and Installation Instructions
can be downloaded from rheemasia.com

PATENTS

This water heater may be protected by one or more patents or registered designs
in the name of Rheem Vietnam Ltd.

TRADEMARKS

® Registered trademark of Rheem Manufacturing Company.
TM Trademark of Rheem Manufacturing Company (Singapore) Pte Ltd.

Note: Every care has been taken to ensure the accuracy in preparation of this
publication. No liability can be accepted for any consequences,
which may arise as a result of its application.

SAFETY, WARNINGS AND PRESSURE RELIEF VALVE

It is important you read the following safety and warning informations before using the water heater.

SAFETY AND WARNINGS

- This water heater is only intended to be operated by persons who have the experience or the knowledge and the capabilities to do so.
- This water heater is not intended to be operated by persons with reduced physical, sensory or mental capabilities i.e. the infirm, or by children. Children should be supervised to ensure they do not interfere with the water heater.
- If the power supply cord is damaged, it must be replaced by a qualified person in order to avoid a hazard. The power supply cord must be replaced with a genuine replacement part available from Rheem. Phone Rheem Service or the nearest authorised Service Agent to arrange for an inspection.
- Do not modify the power supply cord, or immerse it in water, or remove it from the water heater.
- Take care not to touch the power lead with wet hands.
- This water heater uses 220-240 V a.c. power for the electrically operated components. The removal of the electrical cover will expose 220-240 V a.c. wiring. Covers must only be removed by a qualified person.
- This water heater is supplied with a thermostat, an over-temperature cut-out and a pressure relief valve. These devices must not be tampered with or removed. The water heater must not be operated unless each of these devices is fitted and is in working order.

The Rheem warranty may not cover faults if the pressure relief valve or other safety devices are tampered with or if the installation is not in accordance with these instructions.

- The operation of the over-temperature cut-out indicates a possibly dangerous situation. If the over-temperature cut-out operates, it must not be reset and the water heater must be serviced by a qualified person.
- An isolation switch(s) must be installed in the electrical circuit to the water heater in accordance with the local electrical standards, so the water heater can be switched off.
- A pressure relief valve is supplied with the water heater and must always be installed.

Refer to "Pressure Relief Valve" on page 4.

- This water heater must be hung on a wall using the supplied wall brackets and with the water connections on the underside.

- Do not use an upward force from underneath the water heater. Pushing the water heater from underneath may cause it to come loose from its mounting brackets and fall off the wall.
- This water heater is intended to be permanently connected to the water mains and not connected by a hose-set.
- The water heater is supplied with a pressure relief valve with a pressure rating of 800 kPa. If the mains supply pressure exceeds 640 kPa, a pressure limiting valve must be installed.
- For continued safety of this water heater it must be installed, operated and maintained in accordance with the Owner's Guide and Installation Instructions.
- Servicing of a water heater must only be carried out by qualified personnel. Phone Rheem Service or the nearest authorised Service Agent.
- Only a person qualified to install or service a water heater should drain the water heater, if this is required.
- Do not modify this water heater.

PRESSURE RELIEF VALVE

The pressure relief valve is located at the cold water inlet and is essential for the water heater's safe operation. It is possible for the valve to discharge a quantity of water through the drain line during each heating period, if a non-return valve is installed on the cold water line to the water heater.

 **Warning:** Never block the outlet of the valve or drain line for any reason. A pressure relief valve drain must be left open to atmosphere, be installed in a continuously downward direction and in a frost-free environment.

User Maintenance: The easing lever on the pressure relief valve must be operated once every six (6) months to clear any deposits and ensure the valve and its drain line are not blocked. **It is very important the lever is raised and lowered gently.** Refer to "User Maintenance Every Six Months" on page 8.

 **Warning:** Failure to operate the easing lever on the pressure relief valve once every six (6) months may result in the water heater cylinder failing.

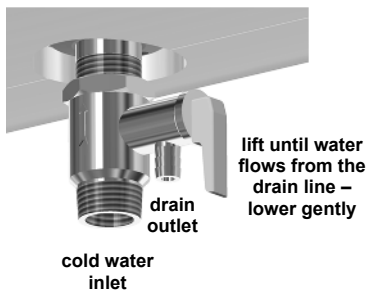
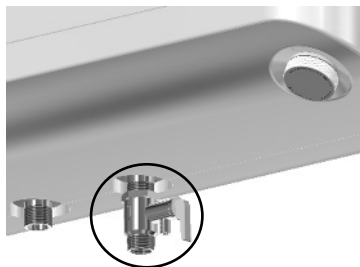

ABOUT YOUR WATER HEATER

MODEL TYPE

The Rheem XWELL™ water heater is suitable for indoor installation only. Water is heated by an electric immersion heating unit with temperature control provided by a thermostat. The thermostat and heating unit operate automatically when heating of the water is required.

The vitreous enamel lined steel cylinder is provided additional corrosion protection by a sacrificial anode and is surrounded by high density polyurethane foam to reduce heat loss and increase performance efficiency. Designed for connection to a mains pressure water supply, the water heater allows connection to more than one hot water outlet. The supply pressure should be greater than 350 kPa for true mains pressure operation to be achieved.

Automatic safety controls are fitted to the water heater to provide safe and efficient operation.

TEMPERATURE ADJUSTMENT

The water heater features a user adjustable Temperature Dial which is connected to the thermostat. Temperature adjustment is made by turning the Temperature Dial:

- clockwise to increase the water temperature.
- anti-clockwise to decrease the water temperature.

The position of the Temperature Dial is relative to the dial setting mark:

- Set at the “●” mark, heating of water will not occur.
- Set at the “MAX” mark, the water will be heated to the maximum temperature of 70°C.

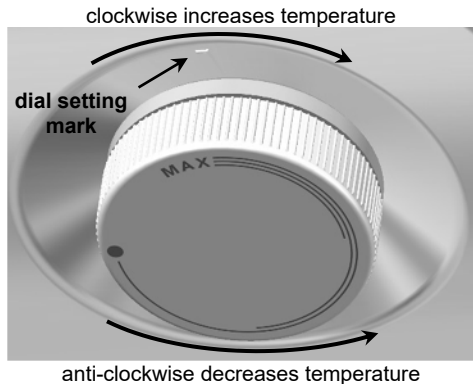

The Temperature Dial incorporates a white light which will either pulse or maintain a steady glow.

Pulsing white light – Heating Mode: The heating unit is on and heating is taking place. It is normal for the heating unit to turn on when hot water is being used, or during standby heat up (recovering heat loss), or when the water heater is switched on after having been off.

Steady white light – Ready Mode: The water temperature has reached the thermostat temperature setting and the heating unit is off.

HOTTER WATER INCREASES THE RISK OF SCALD INJURY

This water heater can deliver water at temperatures which can cause scalding. Check the water temperature before use, such as when entering a shower or filling a bath or basin, to ensure it is suitable for the application and will not cause scald injury.

We recommend and it may also be required by regulations that an approved temperature limiting device be fitted into the hot water pipe work to a bathroom or ensuite when the water heater is installed. This will reduce the risk of scald injury.

TO TURN OFF THE WATER HEATER

If you plan to be away from home for one or two nights, we suggest you leave the water heater switched on.

If it is necessary to turn off the water heater:

- Switch off the electrical supply at the isolating switch (if installed) near the water heater or outside of the bathroom, or at the water heater isolating switch on the switchboard.
- Close the cold water isolation valve at the inlet to the water heater.

TO TURN ON THE WATER HEATER

- Open the cold water isolation valve fully on the cold water line to the water heater.
- Switch on the electrical supply or at the isolating switch (if installed) near the water heater outside of the bathroom, or at the water heater isolating switch on the switchboard.

GOING ON HOLIDAY?

If you plan to be away from home for one or two nights, we suggest you leave the water heater switched on. However, if you plan to stay away more than a few nights, conserve energy by switching the water heater off at the isolating switch (if installed) near the water heater or outside of the bathroom, or at the water heater isolating switch on the switchboard.

Note: When the electrical supply is switched back on, the water heater will take some time to reheat the water.

WATER CHEMISTRY ADVICE AFFECTING WARRANTY

The water heater and its components are not suitable for certain water chemistries. Those chemistries are listed below. If the water heater is connected at any time to a water supply with the following water chemistry, the Rheem warranty will not cover any resultant faults on the components listed below:

Water Chemistry	Component Not Covered
Total Dissolved Solids (TDS) > 600 mg/L	water heater cylinder
Saturation Index (SI) < -2.0	incoloy corrosion resistant heating unit
Saturation Index (SI) > +0.8	incoloy corrosion resistant heating unit
Chlorides > 200 mg/L	incoloy corrosion resistant heating unit

Contact your local Rheem Dealer if a replacement of the heating unit is required.

CAUTION

If the water supply has a Total Dissolved Solids (TDS) content greater than 600 mg/L, there is the possibility the anode may become overactive and hydrogen gas could accumulate in the top of the water heater during long periods of no use.

If, under these conditions, the water heater has not been used for two or more weeks the following procedure should be carried out before using any electrical appliances (automatic washing machines and dishwashers) which are connected to the hot water supply.

The hydrogen, which is highly flammable, should be vented safely by opening a hot tap and allowing the water to flow. There should be no smoking or naked flame near the tap whilst it is turned on. Any hydrogen gas will be dissipated. This is indicated by an unusual spurting of the water from the tap. Once the water runs freely, any hydrogen in the system will have been released.

MAINTENANCE REQUIREMENTS

USER MAINTENANCE EVERY SIX MONTHS

It is recommended user maintenance be performed every six (6) months by the dwelling occupant. The user maintenance includes:

- **Pressure Relief Valve** – Operate the easing lever on the pressure relief valve. **It is very important the lever is raised and lowered gently.** Refer to “Pressure Relief Valve” on page 4.

Ensure a drain line is fitted to the pressure relief valve outlet and the discharge water is directed to the drain.

 **Warning:** Exercise care to avoid any splashing of water by standing clear of the drain line’s point of discharge when operating the valve’s easing lever.

If water does not flow freely from the drain line when the lever is lifted, then the water heater must be checked. Phone Rheem Service or the nearest authorised Service Agent to arrange for an inspection.

- **Safety Device** (On selected models) – Test the Safety Device (Earth Leakage Circuit Breaker) fitted to the power cord. To test the Safety Device:

- Ensure the power outlet to the water heater is switched on.

Indicator Light (B) will be on.

- To test, push Test button (A). Power will cut off, Indicator Light (B) will turn off and Reset button (C) will pop up.

Note: If the Indicator Light (B) remains on, the safety device is not working properly. Turn the water heater off at the power outlet and call for service.

- To reset, push Reset button (C). Power will be reinstated and Indicator Light (B) will turn on.

Note: If the Indicator Light (B) remains off, the water heater is not working properly. Turn the water heater off at the power outlet and call for service.

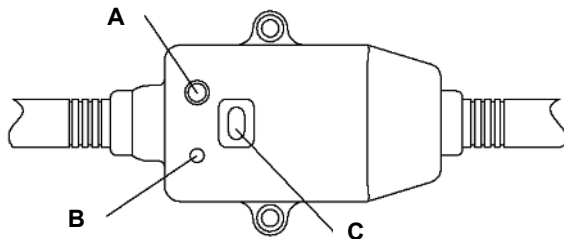

Safety Device (ELCB)

MAJOR SERVICE EVERY FOUR YEARS

It is mandatory a major service be conducted on the water heater every four (4) years. The pressure relief valve should be replaced at intervals not exceeding four (4) years. The checking of the valve performance or replacement should occur more frequently in areas where there is a high incidence of water deposits.

 **Warning:** Servicing of a water heater must only be carried out by qualified personnel. Phone Rheem Service or the nearest authorised Service Agent.

Note: The major service and routine replacement of any components, such as the anode and pressure relief valve, are not included in the Rheem warranty. A charge will be made for this work. Only genuine replacement parts should be used on this water heater.

The major service includes the following actions:

- Replace the pressure relief valve at regular intervals, such intervals not exceeding four (4) years.
- Inspect and if there is any sign of depletion, replace the anode.
If the anode is not replaced, it must be replaced within four (4) years of this service.
- Check the electric heating unit for excessive calcium build-up or corrosion and replace if necessary.
- Visually check the unit for any potential problems.
- Inspect all connections.

Note: The water heater may need to be drained during this service. After the completion of the service, the water heater will take some time to reheat the water.

SAVE A SERVICE CALL

Check the items below before making a service call. You will be charged for attending to any condition or fault that is not related to the manufacture or failure of a part.

NO WATER FLOW FROM THE HOT TAP

- **Is the isolation valve open?**

Check the isolation valve on the cold water line to the water heater is open?

Check if there is water available from other taps in the premises.

If water continues to not be available, phone a plumber.

WATER FROM HOT TAP IS NOT HOT OR NOT HOT ENOUGH

- **Is the electricity switched on?**

Inspect the isolating switch marked “HOT WATER” or “WATER HEATER” at the switchboard and at the isolating switch (if installed) near the water heater or outside of the bathroom and ensure they are turned on.

Check the fuse or circuit breaker marked “HOT WATER” or “WATER HEATER” at the switchboard.

- **Thermostat setting**

Ensure the thermostat setting is appropriate. Adjust the temperature dial to gain additional hot water capacity.

Refer to “Temperature Adjustment” on page 5.



Warning: Hotter water increases the risk of scald injury.

PRESSURE RELIEF VALVE RUNNING

- **Normal Operation**

It is normal and desirable the pressure relief valve allows a quantity of water to escape during the heating cycle, if a non-return valve is installed on the cold water line to the water heater.

This quantity should be equal to approximately 1/50 of the hot water used, as water expands by this volume when heated.

However, if it discharges more than a bucket full of water in 24 hours, there may be another problem.

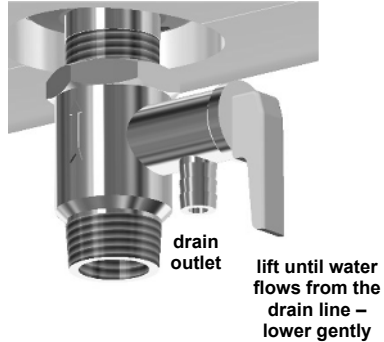

- **Continuous dribble**

Try gently raising the easing lever on the pressure relief valve for a few seconds (refer to "Pressure Relief Valve" under User Maintenance Every Six Months on page 8.). This may dislodge a small particle of foreign matter and clear the fault. Release the lever gently.

- **Steady flows for long period (often at night)**

This may indicate the mains water pressure sometimes rises above the designed pressure of the water heater. Ask a plumber to fit a pressure limiting valve.

 **Warning:** Never replace the pressure relief valve with one of a higher pressure rating.

- **Continuous flow of very hot water or steam from the pressure relief valve drain**

The water heater **must** be switched off at the switchboard or isolating switch. Phone Rheem Service or the nearest authorised Service Agent to arrange for an inspection.

IF YOU HAVE CHECKED ALL THE FOREGOING AND STILL BELIEVE YOU NEED ASSISTANCE, PHONE RHEEM SERVICE OR THE NEAREST AUTHORISED SERVICE AGENT.

INSTALLATION – GENERAL

INSTALLATION STANDARDS

The water heater must be installed:

- by a qualified person, and
- in accordance with the installation instructions, and
- in compliance with national plumbing and electrical standards, and
- in compliance with all local codes and regulatory authority requirements.

All packaging materials must be removed from the water heater prior to its installation.

WATER HEATER LOCATION

The water heater is suitable for indoor installation only. The water heater should be installed close to the most frequently used outlet and its position chosen with safety and service in mind. The water heater and power cord should be positioned to minimise exposure to splashing water.

The water heater is designed to be mounted onto a wall with the water connection fittings pointing toward the floor. Clearance must be allowed for servicing of the water heater. A minimum distance of 30 mm is required from the top of the water heater to the ceiling. For an XS model, a minimum distance of 500 mm is required from the right hand side to a wall or obstruction. Refer to dimensional drawings on pages 15 and 16.

Make sure the pressure relief valve lever is accessible, the electrical cover, thermostat, heating unit and anode can be removed for service, and the pressure relief valve drain line can terminate adjacent to a nearby floor trap. You must be able to read the information on the rating plate. Remember you may have to take the entire water heater out later for servicing.

WALL MOUNTING OF THE WATER HEATER

The wall must be of a type able to accept the fasteners to secure or accept the brackets which support the water heater and also take the weight of the water heater when full of water. Refer to pages 15 [XC models] and 16 [XS models] for the weight of the water heater when full of water.

The water heater is provided with two fasteners and two wall plugs suitable for an installation on masonry or concrete wall type. Check these fasteners are suitable for the wall onto which the water heater is to be mounted.

If not suitable, or for other types of wall, it is necessary to select and use alternative fasteners suitable for the application. The fasteners must be capable of bearing the full weight of the water heater. Refer to the fastener manufacturer's information and recommendations for the type of fastener to use for the wall or frame type and load bearing requirements.

To mount the water heater on the wall:

- A minimum distance of 30 mm is required from the top of the water heater to the ceiling for XC and XS models.
- Do not drill holes in the sides of the water heater. Any damage to the water heater caused by drilling will void the Rheem warranty.
- **Caution:** Beware of electrical cables and water pipes when drilling into the wall.

XC models

- An XC model is supplied with one mounting bracket. The mounting bracket is to be secured to the wall prior to mounting the water heater.
- Using the mounting template from the water heater carton, mark the position of the two holes to be drilled for locating the fasteners on the wall.
- The mounting bracket must be horizontal. Use a spirit level to ensure the hole markings are horizontal.
- Check the distance between the hole markings is as shown on the dimensional drawing and table on page 15.
- Drill holes into the wall. Use either a Ø10 mm masonry drill if using the fasteners provided, or a suitable drill bit size if using other fasteners suitable for the wall construction.
- If using the fasteners provided, insert the plastic wall plugs into the holes prior to locating and hanging the bracket.
- If using another type of fastener, follow its manufacturer's instructions for fastening. Ensure the fastener head size is not greater than 8 mm in depth so it does not foul against back of the water heater.
- Locate the bracket over the holes with the prongs pointing upwards, and screw in the fasteners tightly to secure the bracket to the wall.
- Hang the water heater on the bracket with the prongs fitting up into the housings at the rear of the water heater. Check it is installed level (horizontal) and hung securely.

XS models

- A minimum distance of 500 mm is required from the right hand side of an XS model to a wall or obstruction.
- An XS model is supplied with two mounting brackets pre-fitted to the back of the water heater.
- Using the mounting template from the water heater carton, mark the position of the two holes to be drilled for locating the fasteners on the wall.
- The installed water heater must be horizontal. Use a spirit level to ensure the hole markings are horizontal.

- Check the distance between the hole markings is as shown on the dimensional drawings on page 15.
- Drill holes into the wall. Use either a Ø10 mm masonry drill if using the fasteners provided, or a suitable drill bit size if using other fasteners suitable for the wall construction.
- If using the fasteners provided, insert the plastic wall plugs into the holes and screw in the fasteners. Leave a 6 mm to 8 mm gap between the screw head flange and the wall surface to allow the water heater brackets to fit over behind the fastener head.
- If using another type of fastener, follow its manufacturer's instructions for fastening. Ensure the fastener head size is:
 - from 11 mm to 13 mm in diameter, to allow the brackets to fit over the fastener heads and not to disengage from the bracket, and
 - 8 mm or less in depth so it does not foul against back of the water heater.

When screwing in the fastener, leave a 6 mm to 8 mm gap between the screw head flange and the wall surface to allow the water heater brackets to fit over behind the fastener head.

- Hang the water heater on the wall with the brackets fitting over the fastener heads and check it is installed level (horizontal) and hung securely.

HOT WATER DELIVERY

This water heater can deliver water at temperatures which can cause scalding.

Consideration should be given to installing an approved temperature limiting device in the hot water pipe work from the water heater to a bathroom, ensuite or other abluion area. This may also be required by local regulations. This will reduce the risk of scald injury. Refer to the diagram Installation with a Temperature Limiting Device on page 19.

If a pressure limiting valve is installed on the cold water line to the water heater and the cold water line to a temperature limiting device branches off before this valve or from another cold water line in the premises, then a pressure limiting valve of an equal pressure setting may be required prior to the temperature limiting device.

ANODE

The vitreous enamel lined cylinder of the water heater is only covered by the Rheem warranty when the total dissolved solids (TDS) content in the water is less than 600 mg/L. For water chemistries with a TDS greater than 600 mg/L, any resultant faults will not be covered by the Rheem warranty.

If the water supply has a TDS greater than 600 mg/L, there is the possibility the anode may become overactive and hydrogen gas could accumulate in the top of the water heater during long periods of no use. In areas where this is likely to occur, the installer should instruct the householder on how to dissipate the gas safely (refer to "Caution" on page 7).

DIMENSIONS AND TECHNICAL DATA – XC MODELS

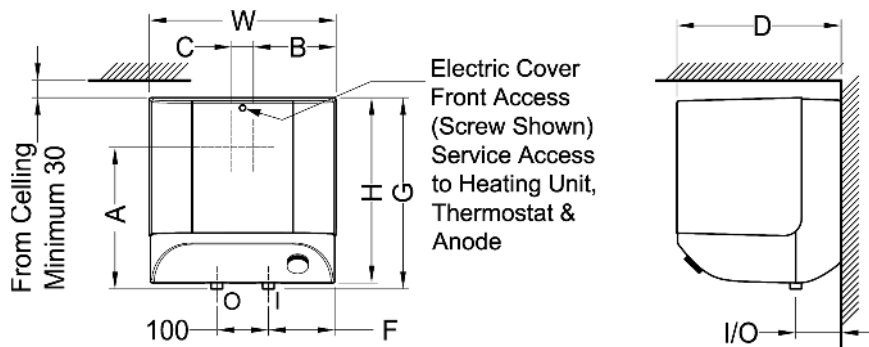

Fitting connections: O = outlet (red), I = inlet (blue)
 All dimensions are in mm

Model		XC-10	XC-15	XC-30	
Nominal Storage Capacity	Litres	10	15	30	
Voltage	Volts	220-240	220-240	220-240	
Frequency	Hz	50-60	50-60	50-60	
Dimensions					
Mounting holes to water connections	A	mm	290	290	356
Mounting holes to right hand jacket	B	mm	151	151	193
Spacing between mount holes	C	mm	61	61	61
Depth	D	mm	251	318	380
Inlet connection to right hand jacket	F	mm	129	129	383
Height including fittings	G	mm	371	371	460
Height	H	mm	356	356	447
Width	W	mm	363	363	447
Water connection from wall	I/O	mm	90	90	120
Thermostat setting (factory setting)	°C	70	70	70	
Pressure Relief Valve Setting	kPa	800	800	800	
Maximum inlet water pressure	kPa	640	640	640	
Water inlet/outlet connections		G 1/2 B	G 1/2 B	G 1/2 B	
Approx. Weight empty	kg	8	9	14	
Approx. Weight full	kg	18	24	44	

All models are suitable for indoor installation only, ingress protection = IP24.
 Technical data is subject to change.

DIMENSIONS AND TECHNICAL DATA – XS MODELS

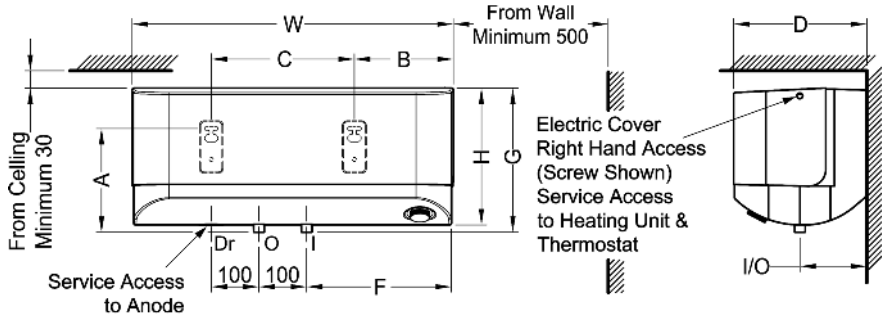

Fitting connections: O = outlet (red), I = inlet (blue), Dr = anode
 All dimensions are in mm

Model		XS-20	XS-30	
Nominal Storage Capacity	Litres	20	30	
Voltage AC	Volts	220-240	220-240	
Frequency	Hz	50-60	50-60	
Dimensions				
Mounting holes to water connections	A	mm	221	234
Mounting holes to right hand jacket	B	mm	208	235
Spacing between mount holes	C	mm	300	326
Depth	D	mm	278	318
Inlet connection to right hand jacket	F	mm	304	345
Height including fittings	G	mm	306	346
Height	H	mm	287	330
Width	W	mm	674	760
Water connection from wall	I/O	mm	143	163
Thermostat setting (factory setting)	°C	70	70	
Pressure Relief Valve Setting	kPa	800	800	
Maximum inlet water pressure	kPa	640	640	
Water inlet/outlet connections		G 1/2 B	G 1/2 B	
Approx. Weight empty	kg	13	17	
Approx. Weight full	kg	33	47	

All models are suitable for indoor installation only, ingress protection = IP24.
 Technical data is subject to change.

CONNECTIONS – PLUMBING

All plumbing work must be carried out by a qualified person and in compliance with national and local plumbing standards and regulatory authority requirements.

Water Inlet and Outlet: The cold and hot water connections are on the underside of the water heater. The cold inlet has a blue marking and the hot outlet has a red marking. The connection sizes are:

- Hot water connection G 1/2 B
- Cold water connection G 1/2 B

Pressure Relief Valve: A pressure relief valve is supplied with the water heater and must be fitted before the water heater is operated. The pressure relief valve is to be screwed into the cold water inlet fitting with the drain outlet facing in a downward direction. The pressure relief valve contains a sealing rubber washer to seal against water leakage. A drain line must be fitted to the pressure relief valve drain outlet. Refer to “Pressure Relief Valve Drain” on page 18.

Isolation Barrier Protection – Malaysia only: Water Heaters supplied in Malaysia have Isolation Barrier Protection devices supplied fitted to the cold water inlet and hot water outlet of the water heater. These must be left in position. The pressure relief valve screws into the inlet of the Isolation Barrier Protection device on the cold water inlet.

Connecting Pipe Work: Connecting pipe work must be capable of withstanding 800 kPa water pressure and the hot water pipe work must be capable of withstanding 70°C water temperature. All pipe work must be cleared of foreign matter before connection and purged before attempting to operate the water heater.

A disconnection union must be provided at the inlet of the pressure relief valve and at the hot water outlet on the water heater to allow for disconnection of the water heater. A braided flexible hose or semi-flexible connector may be used for connection to the water heater, where permitted by local authorities. This water heater is intended to be permanently connected to the water mains and not connected by a hose-set.

All olive compression fittings must use brass or copper olives. Use an approved thread sealant such as Teflon tape on all sealing threads.

The water heater has a plastic diffuser in the inlet fitting and a dip tube in the outlet fitting. These must be in place for the water heater to function properly. They will be pushed into the correct position as the fitting is screwed in. Do not remove them or use heat nearby, as damage can result.

To achieve true mains pressure operation, the cold water line to the water heater should be the same size or bigger than the hot water line from the water heater.

The pipe sizing for hot water supply systems should be carried out by persons competent to do so, choosing the most suitable pipe size for each individual application. Reference to the technical specifications of the water heater and local regulatory authority requirements must be made.

Cold Water Valves: An isolation valve (shut off valve) must be installed on the cold water line to the water heater. A pressure limiting valve is recommended to be installed if the mains supply pressure exceeds 640 kPa. Local regulations may require a non-return valve to be installed. Refer to the schematic diagrams on page 19.

Pipe Insulation: It is recommended to insulate the hot water pipe work to reduce heat loss and also prevent any contact with the hot pipe. It may be necessary to insulate the cold water line to and the hot water line from the water heater in accordance with local regulatory authority requirements.

Pressure Relief Valve Drain: A drain line must be fitted to the pressure relief valve to carry the discharge clear of the water heater. The pressure relief valve outlet has a 7 mm barb connection. Connect the drain line securely to the valve using a pipe clamp. Cable ties **must not** be used.

The drain line must have a minimum internal diameter of 7 mm and be capable of maintaining its internal area under all operating conditions. Water discharged from the outlet of the drain line can be of a high temperature and under certain conditions, boiling or steaming.

The drain line from the valve to the point of discharge must be as short as possible, have a continuous fall all the way from the water heater to the discharge outlet, be supported over any length that is not vertical, be left open to atmosphere and have no tap, valves or other restrictions in the pipe work. The outlet of a drain line must be in such a position that flow out of the pipe can be easily seen, but arranged so discharge will not cause injury, damage or nuisance.

The termination point of a drain line must comply with the requirements of national and local plumbing standards and regulatory authorities. A termination point of between 150 mm and 300 mm above a floor trap is recommended.

 **Warning:** As the function of the pressure relief valve on this water heater is to discharge high temperature water under certain conditions, it is recommended pipe work downstream of the pressure relief valve be capable of carrying boiling water. Failure to observe this precaution may result in damage to pipe work and property.

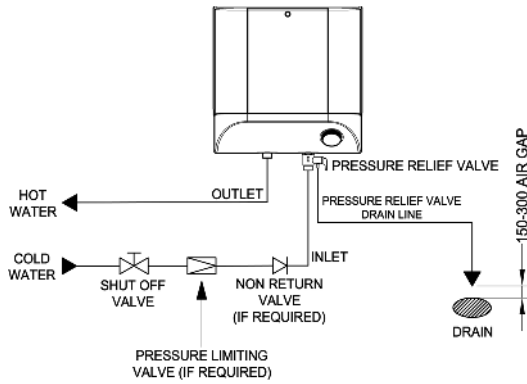

Installation Standard

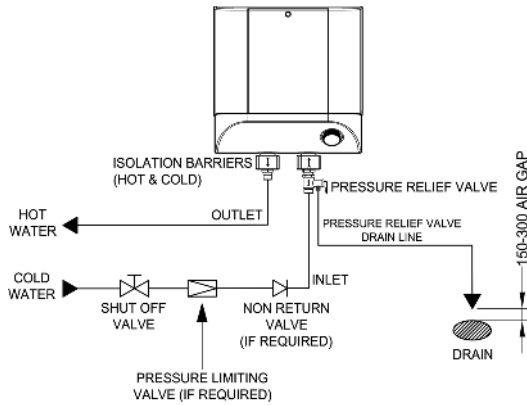

Installation with Isolation Barriers (Malaysia only)

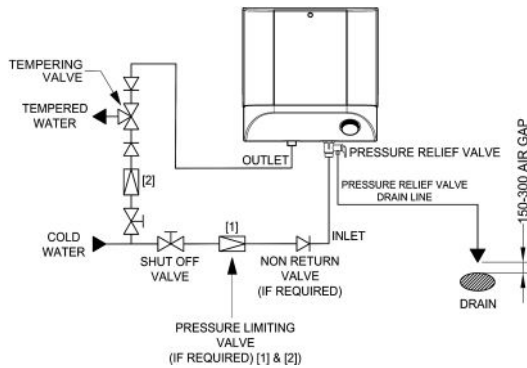

Installation with a Temperature Limiting Device

CONNECTIONS – ELECTRICITY

The power supply to the water heater must not be switched on until the water heater is filled with water and a satisfactory megger reading is obtained. There is NO WARRANTY for the dry firing of a heating unit.

All electrical work and permanent wiring must be carried out by a qualified person and in compliance with national and local electrical standards and regulatory authority requirements.

WATER HEATER

The water heater is designed for connection to a 220-240 V a.c. 50-60 Hz single phase power supply. The electrical power supply cable from the switch board to a junction box must be correctly sized to safely carry the maximum current draw of the heating unit in the water heater. Refer to the rating label on the water heater for the heating unit size.

An isolating switch(s) must be installed at the switchboard or near the water heater or outside of the bathroom in accordance with regulatory requirements.

The water heater is fitted with a supply cord and shoelace wire terminals and must be directly connected to the mains electricity supply with an Earth, Live and Neutral wire connection.

THERMOSTAT SETTING

The thermostat on an XC and XS series water heater is user adjustable from 10°C to 70°C. The factory setting of the thermostat is 70°C. The thermostat is adjusted by turning the Temperature Dial anticlockwise to decrease the temperature setting and clockwise to increase the temperature setting.

WIRING DIAGRAM

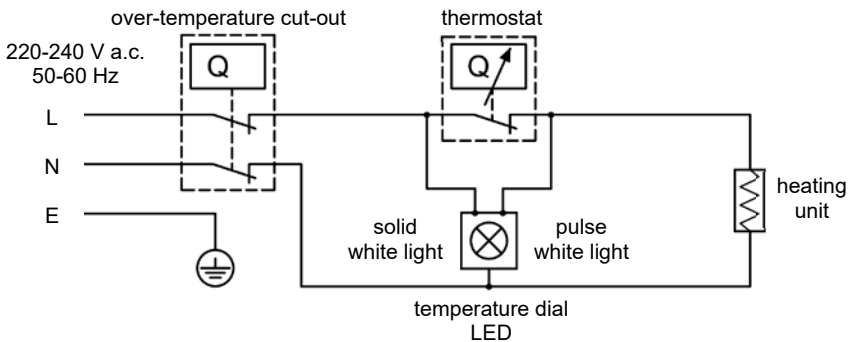

Electrical Circuit for XC and XS Series Water Heaters

COMMISSIONING

TO FILL AND TURN ON THE WATER HEATER

The power supply to the water heater must not be switched on until the water heater is filled with water and a satisfactory megger reading is obtained.

- Open all of the hot water taps supplied from the water heater.
- Open the cold water isolation valve fully on the cold water line to the water heater.
Air will be forced out of the taps.
- Close each tap as water flows freely from it.
- Check the pipe work for leaks.
- Switch on the electrical supply at the isolating switch (if installed) near the water heater or outside of the bathroom, and at the water heater isolating switch on the switchboard.

Explain to the householder or a responsible officer the functions and operation of the water heater. Upon completion of the installation and commissioning of the water heater, leave this guide with the householder or a responsible officer.

TO TURN OFF THE WATER HEATER

If it is necessary to turn off the water heater on completion of the installation, such as on a building site or where the premises is vacant, then;

- Switch off the electrical supply at the isolating switch (if installed) near the water heater or outside of the bathroom, and at the water heater isolating switch on the switchboard.
- Close the cold water isolation valve at the inlet to the water heater.

DRAINING THE WATER HEATER

 **Warning:** Exercise care, as water discharged from the water heater may be of a very high temperature.

To drain the water heater:

- Switch off the electrical supply at the isolating switch (if installed) near the water heater or outside of the bathroom, or at the water heater isolating switch on the switchboard.
- Close the cold water isolation valve at the inlet to the water heater.
- Open a hot water tap.
- Ensure there is a drain line attached to the pressure relief valve outlet. If required, attach a drain line and direct it to a drain.
- Operate the pressure relief valve lever - do not let the lever snap back or you will damage the valve seat.

Allow the water to drain from the pressure relief valve drain.

- Alternatively if the water heater is not draining or is slow to drain;
 - Return the pressure relief valve lever to the closed position.
 - Open the cold water isolation valve at the inlet to the water heater.
 - Allow hot water to flow from the hot tap until it runs cold.
 - Close the hot tap.
 - Close the cold water isolation valve at the inlet to the water heater.
 - Undo the pressure relief valve at the cold water inlet to the water heater, attach a hose to the water heater inlet and direct the hose to a drain.

Exercise care as water will begin to discharge from the water heater when the pressure relief valve is removed.

- Disconnect the union at the hot water outlet of the water heater.

Water will now flow from the hose attached to the cold water inlet.

This page is intentionally blank.

WARRANTY

The standard warranty applicable for this Rheem product and the term of the warranty may differ based on the country of purchase. Depending on your country of purchase, the warranty may be provided by a member of the Rheem Manufacturing Company group of companies (hereinafter referred to as "Rheem") or by Rheem's authorised partners. Where the warranty is provided by Rheem's authorized partners, these partners shall be exclusively responsible for all warranty related services, including the term of the warranty. Please contact your local Rheem retailer to enquire about the steps necessary to qualify for the applicable warranty and ensure that you complete those steps. Please ensure you retain a copy of your proof of purchase. For more information on the applicable warranty on your Rheem product, please contact your local Rheem retailer.